

MULTI 18,000 BTUH Multi-zone 4-Way Cassette

**Model:
KM18HKDI**



Item	Unit	Specification
Model	—	KM18HKDI
System and Electrical Ratings		
Rated Cooling Capacity	Btu/h	15355
Rated Heating Capacity	Btu/h	17061
Sound Pressure (High/Low)	dB(A)	47/39
Air Flow (max)	CFM	353
Normal Operational Voltage	—	208-230 V, 1 Ph, 60 Hz
Voltage Range	V	187-253
MCA/ Power Cable Size	A	1
Unit and Pipe Data		
Communication Cable Wire Size	AWG	14-4
Unit Dimensions (L×H×D)	mm	570 x 230 x 570
	Inch	22.5 x 9.0 x 22.5
Grille Dimensions (L×H×D)	mm	650 x 36 x 650
	Inch	25.6 x 1.5 x 25.6
Weight (Net/Shipping)	lbs	40/51
Air Filter	—	Netted polypropylene
Condensate Drain Lift (Height)	mm	305
	Inch	12
Drain Size (OD)	mm	31
	Inch	1.2
Refrigerant Type	—	R410A
Gas Pipe Size (OD)	Inch	1/2
Liquid Pipe Size (OD)	Inch	1/4
Connection Method	—	Flared

Job Name:

Schedule Reference:

Date:



Outline and Physical Dimensions of KM18HKDI.

Units: inch (mm)

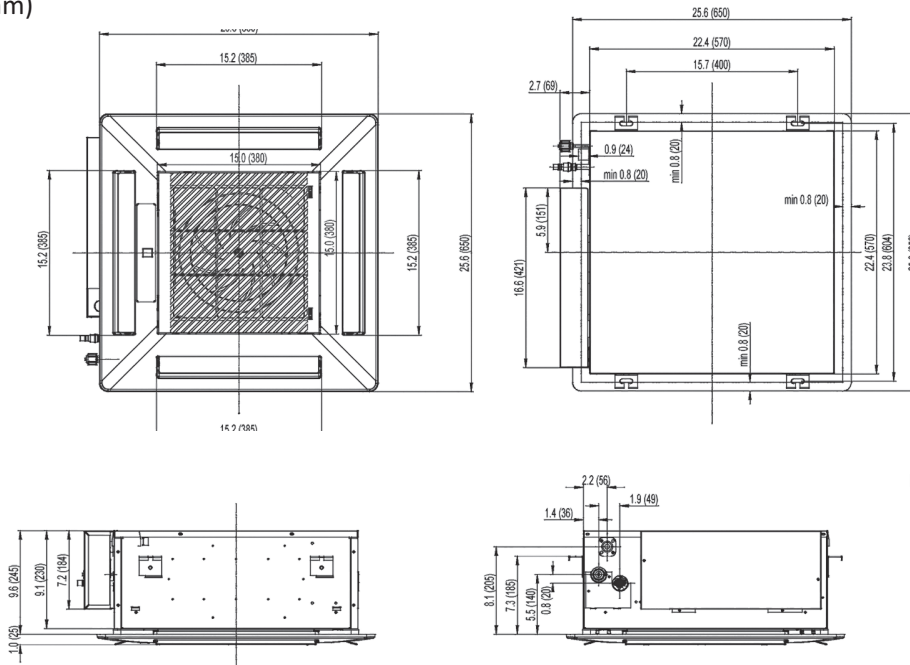

Note: Size refrigerant lines

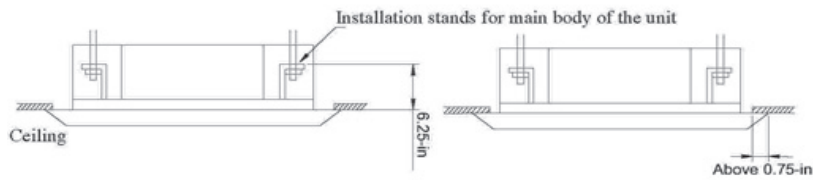

MINIMUM CLEARANCES

